

REVISION RECORD				
SYM	DESCRIPTION	BY	DATE	APPD
A	RELEASED FOR MFG.	RA	6/12/19	RA

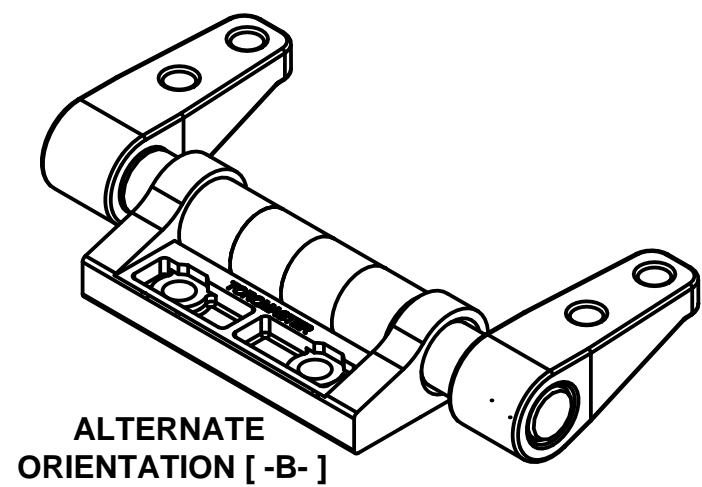

Available Torque per Hinge  
10-80 inch pounds  
Balanced or Unbalanced Torque  
(Symmetric / Asymmetric)

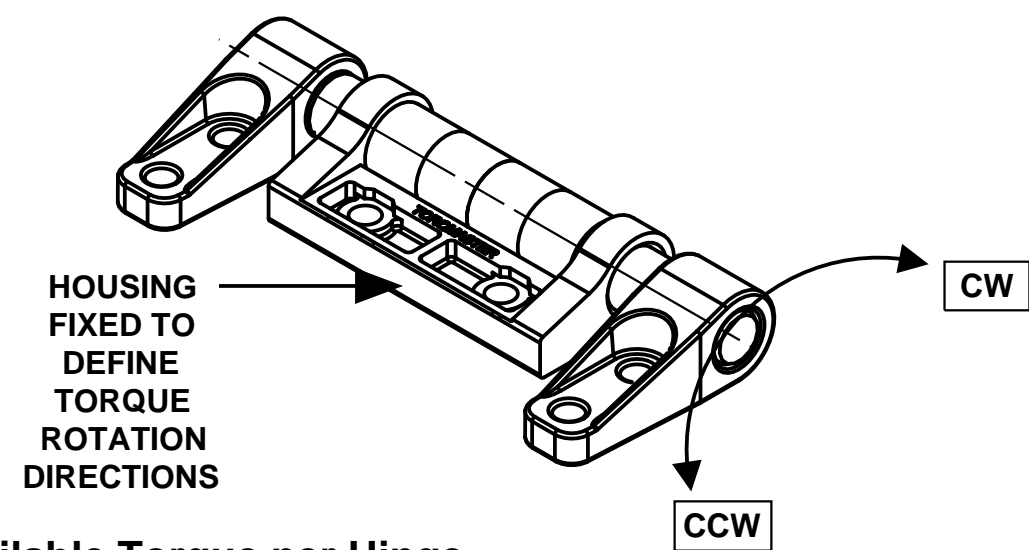
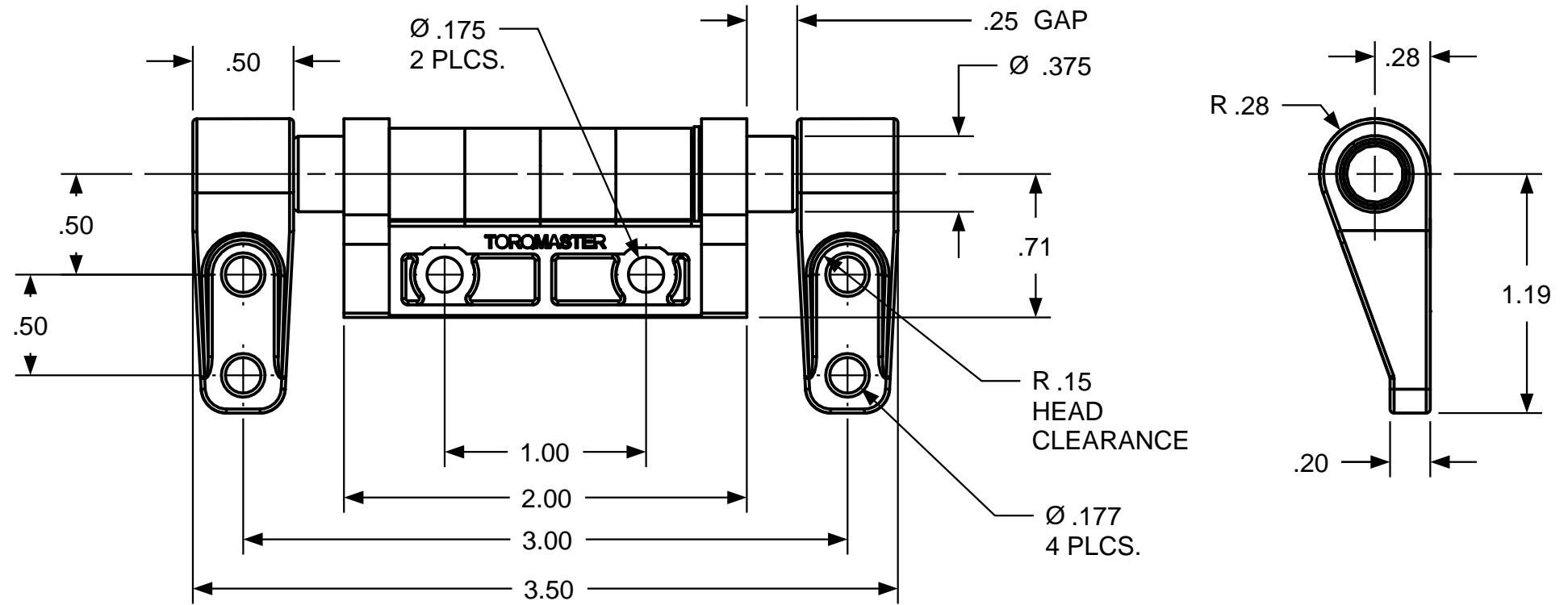

USED ON	SOLID	REV	TOLERANCES		ENGLISH		TORQ MASTER INTERNATIONAL		200 HARVARD AVE STAMFORD, CT USA	
STANDARD	ZA152	A	ENGLISH	METRIC						
NEXT ASSY	N/A		.XX ±.015 IN	.X ±.4 MM	DRAWN BY	DATE	MATERIAL N/A			
<b>QUANTITY</b>			.XXX ±.005 IN	.XX ±.13 MM	RA	6/12/19	TITLE HINGE INTERFACE			
PER ASSY, PCS			.XXXX ±.0002 IN	.XXX ±.05 MM	CHECKED BY	DATE	SIZE B		REV A	
TOTAL, PCS						RA	6/12/19	ZE 375 ZA 152		
THIS INFORMATION IS PROPRIETARY TOTORQMASTER, INTL. THE POSSESSOR AGREES TO MAINTAIN IT IN CONFIDENCE, NOT REPRODUCING OR REVEALING IT IN WHOLE OR IN PART.							SCALE NTS		SHEET 1 OF 1	