

ROTATION
AS SHOWN FOR
CALLOUT OF
TORQUE
CW = CCW

ALTERNATE CONFIGURATION
AVAILABLE (A = AS DRAWN)

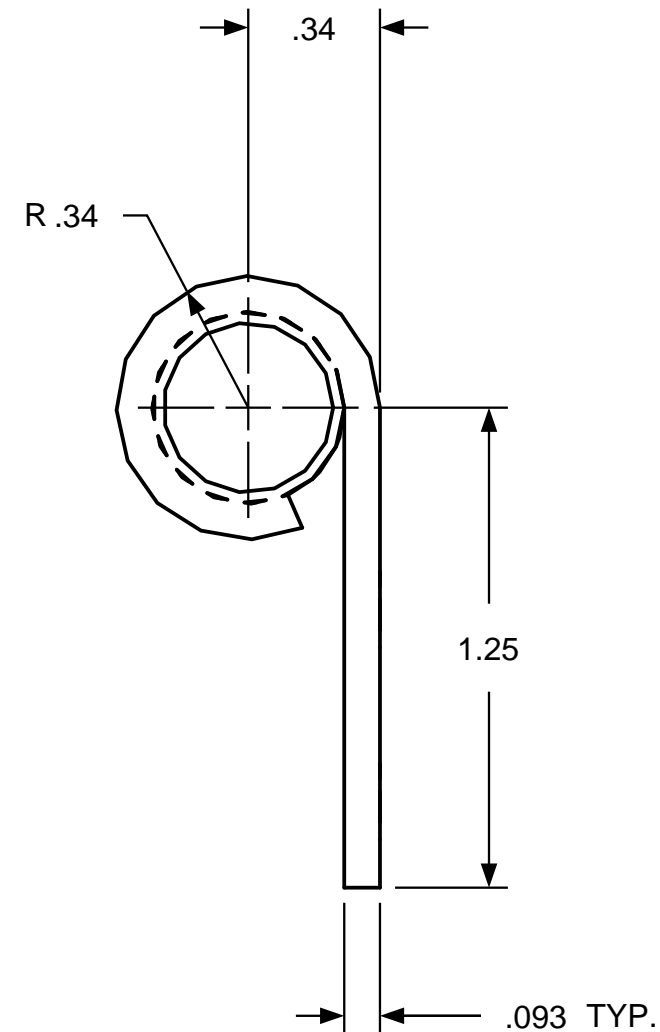
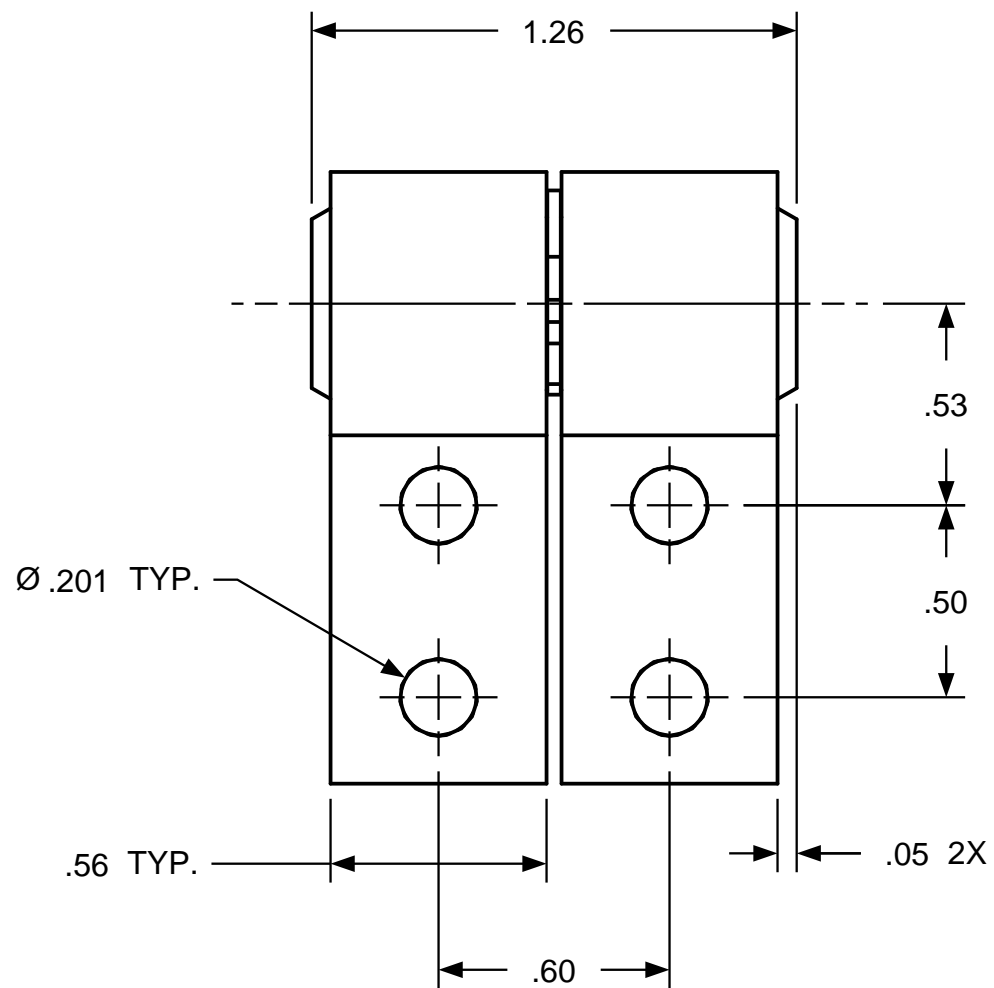
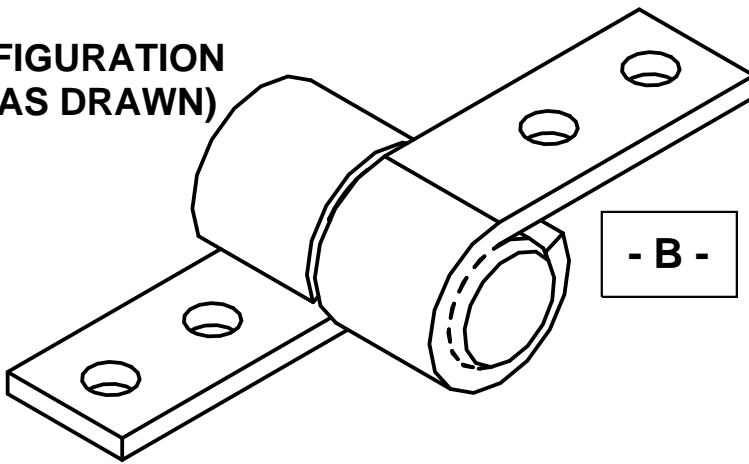
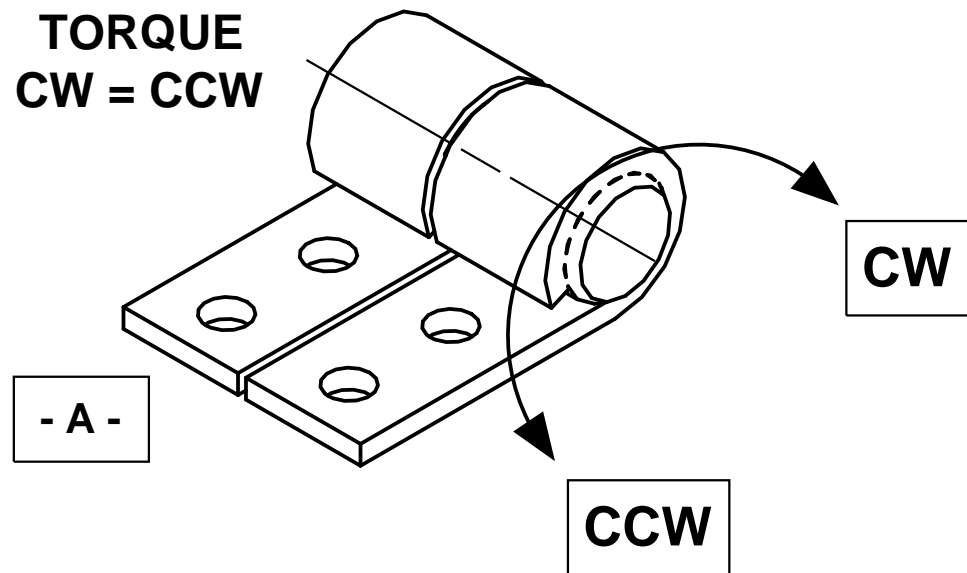

REVISION RECORD				
SYM	DESCRIPTION	BY	DATE	APPD
A	RELEASED FOR MFG.	RA	6/17/19	RA

USED ON	SOLID	REV	TOLERANCES		ENGLISH / METRIC		TORQ MASTER INTERNATIONAL		
STD 500	103	A	ENGLISH	METRIC			200 HARVARD AVE STAMFORD, CT USA		
NEXT ASSY	N/A		.XX ±.015 IN	.X ±.4 MM	DRAWN BY	DATE	MATERIAL N/A		
QUANTITY			.XXX ±.005 IN	.XX ±.13 MM	RA	6/17/19	TITLE HINGE, INTERFACE		
PER ASSY, PCS			.XXXX ±.0002 IN	.XXX ±.05 MM	CHECKED BY	DATE	SIZE B		REV A
TOTAL, PCS					RA	6/17/19	SB 500 SB 103		
THIS INFORMATION IS PROPRIETARY TOTORQMASTER, INTL. THE POSSESSOR AGREES TO MAINTAIN IT IN CONFIDENCE, NOT REPRODUCING OR REVEALING IT IN WHOLE OR IN PART.							SCALE NTS		SHEET 1 OF 1