

REVISION RECORD				
SYM	DESCRIPTION	BY	DATE	APPD
B	REDRAWN ON NEW FORMAT NO CHANGE.	RMF	4/11/01	DJC
C	REVISED PER ECN 03026.	RMF	4/3/03	DJC
D	REVISED PER 08016	WB	10JUL08	ER

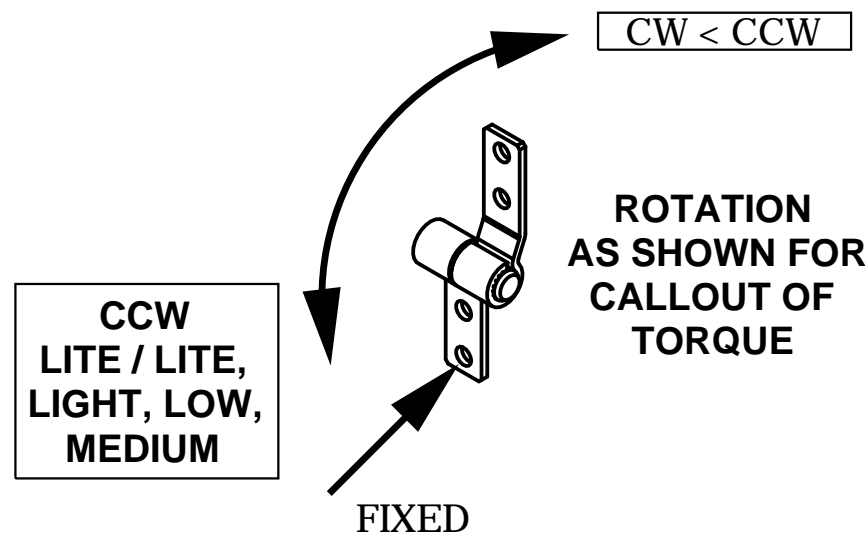

ROTATION AS SHOWN FOR CALLOUT OF TORQUE

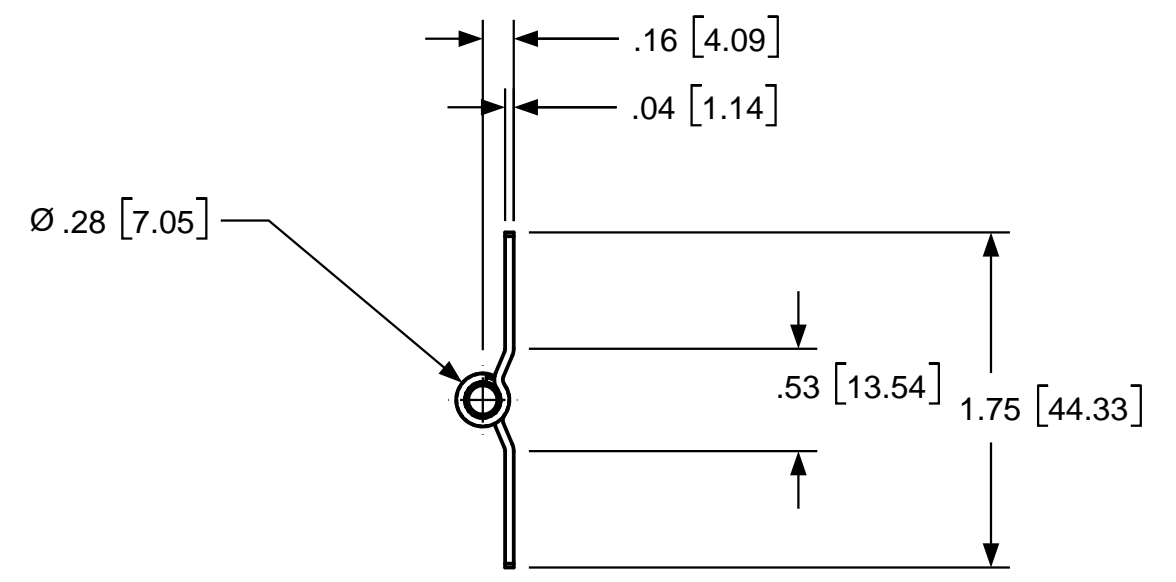
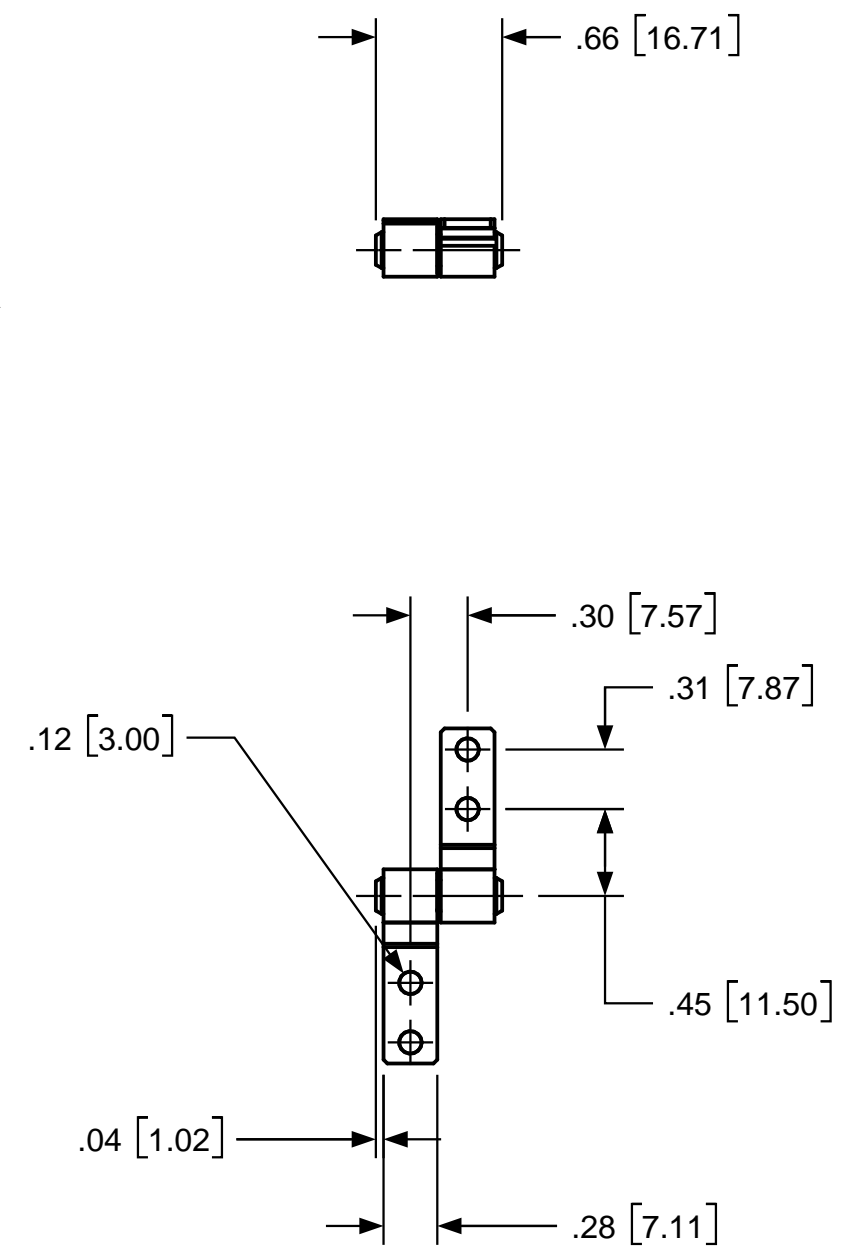

TORQUE
LITE / LITE CCW .5 - 1.5 lb. in.
LIGHT CCW 1.0 - 2.5 lb. in
LOW CCW 2.5 - 4.5 lb in
MEDIUM CCW 4.5 - 6.0 lb. in

UNITS: INCHES [MILLIMETERS]

USED ON	SOLID	REV	TOLERANCES		DRAWN BY	DATE	ENGLISH		TorqMaster, Inc. Stamford, CT USA	
STANDARD	108	B	ENGLISH		RMF	12/12/00	MATERIAL		N/A	
NEXT ASSY	N/A		.XX ±.015 IN		CHECKED BY	DATE	TITLE		HINGE INTERFACE	
QUANTITY			.XXX ±.005 IN		DJC	2/9/01	SIZE		SB 188 SB 108	
PER ASSY, PCS	-		.XXXX ±.0002 IN				REV		D	
TOTAL, PCS	-		ANGLES ±0.5°				SCALE		1:1	
THIS INFORMATION IS PROPRIETARY TO TORQMASTER, INTL. THE POSSESSOR AGREES TO MAINTAIN IT IN CONFIDENCE, NOT REPRODUCING OR REVEALING IT IN WHOLE OR IN PART.							SHEET		1 OF 1	