

REVISION RECORD

SYM	DESCRIPTION	BY	DATE	APPD
D	REVISED FOR ALTERNATE SHAFT PROCESSING	RA	1/2010	

LEFT HAND

RIGHT HAND

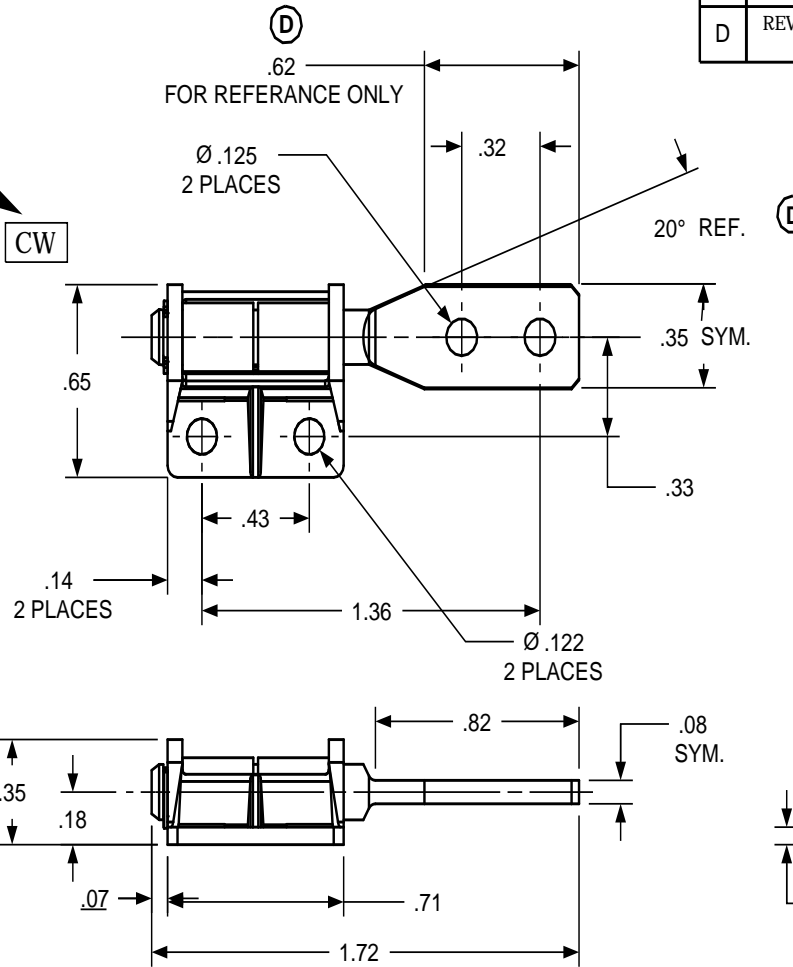
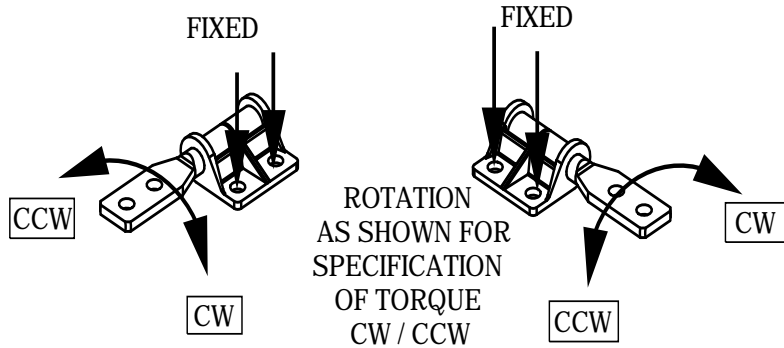

TORQUE

GEOMETRY	TORQUE		HAND
	CW TORQUE	CCW TORQUE	
ZE-188-CF-101	-1	-1	-L
ZE-188-CF-101	-1	-1	-R
ZE-188-CF-101	-4	-4	-L
ZE-188-CF-101	-4	-4	-R

CUSTOM TORQUE CONFIGURATIONS AVAILABLE. FOR QUOTE: www.torqmaster.com 1-888-41 HINGE

USED ON	SOLID	REV	TOLERANCES	DRAWN BY	DATE	TorqMaster, Inc. Stamford, CT USA	
STANDARD	101		ENGLISH	RA	5/9/97	ENGLISH	
NEXT ASSY	NONE		.XX ±.015 IN .XXX ±.005 IN	CHECKED BY	DATE	MATERIAL	N/A
QUANTITY				DJC	5/9/97	TITLE HINGE INTERFACE	
PER ASSY, PCS	-					SIZE	
TOTAL, PCS	-					B	
THIS INFORMATION IS PROPRIETARY TO TORQMASTER, INTL. THE POSSESSOR AGREES TO MAINTAIN IT IN CONFIDENCE. NOT REPRODUCING OR REVEALING IT IN WHOLE OR IN PART.						ZE 188 CF 101	
SCALE 1:1		SHEET 1 OF 1		REV D			