

REVISION RECORD				
SYM	DESCRIPTION	BY	DATE	APPD
C	REDRAWN ON NEW FORMAT, NO CHANGES.	RMF	8/30/00	DJC
D	REVISED PER ECN 04030.	RMF	2/13/04	DJC
E	SHAFT POSITION CORRECTED, NEW HOUSING	VC	10/21/10	VC

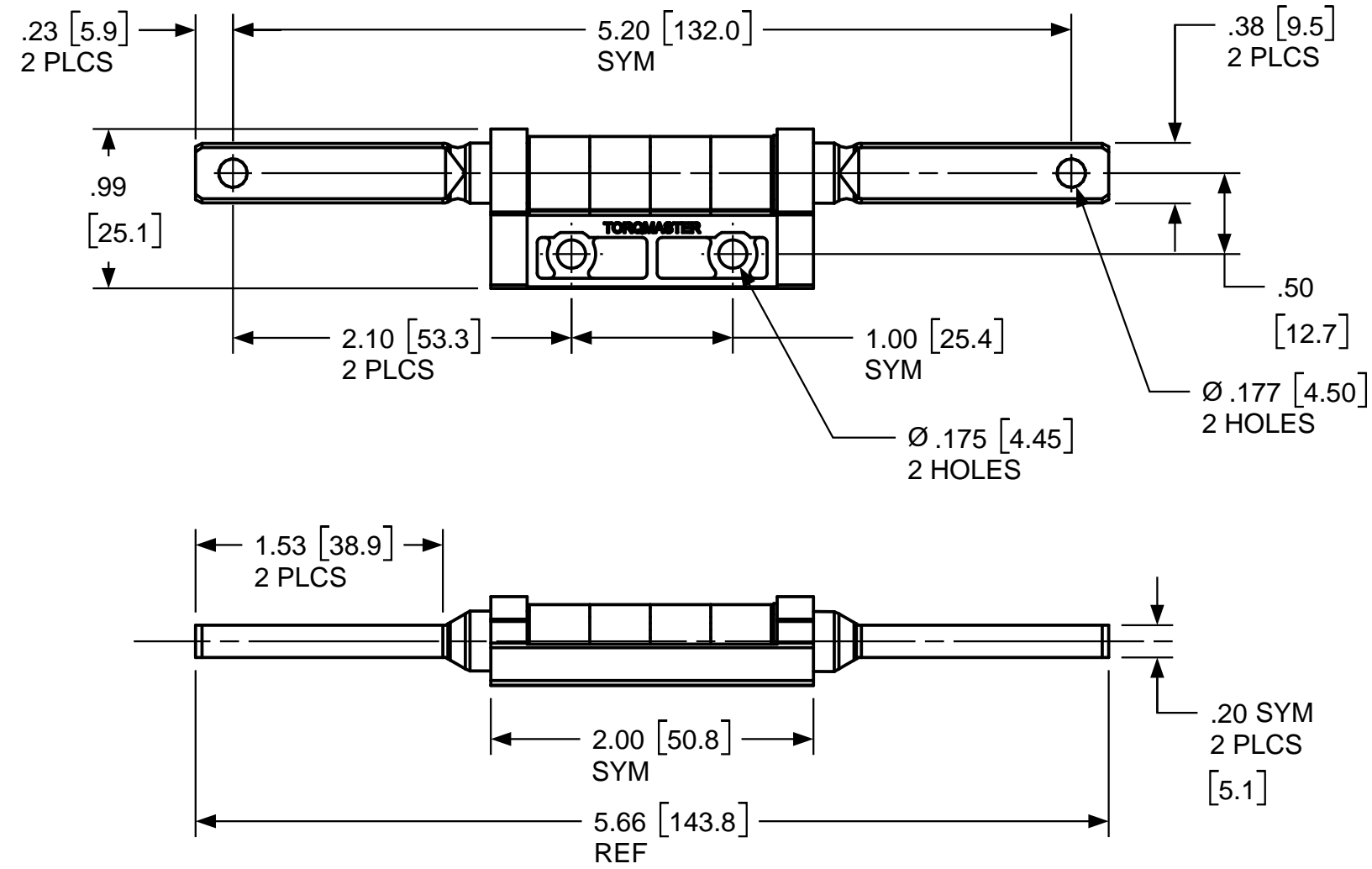
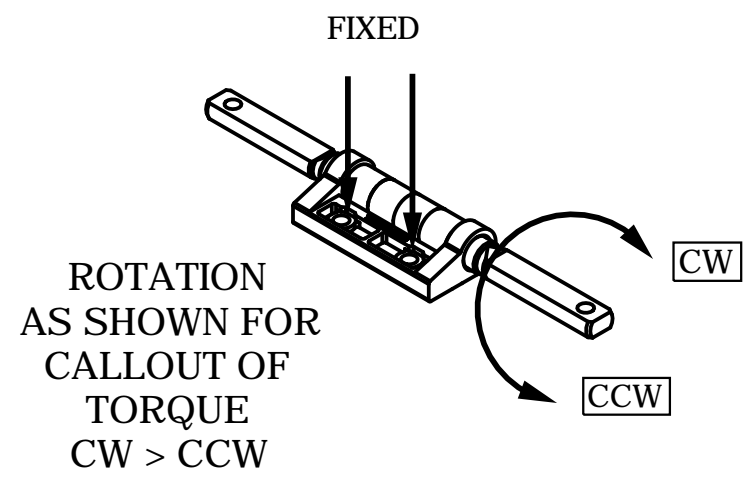

TORQUE

GEOMETRY	CW TORQUE	CCW TORQUE
ZE 375 CF 152	50	X
ZE 375 CF 152	X	50
ZE 375 CF 152		
ZE 375 CF 152		
ZE 375 CF 152		
ZE 375 CF 152		

CUSTOM TORQUE CONFIGURATIONS AVAILABLE. FOR QUOTE:
 www.torqmaster.com
 1 - 888 - 41 - HINGE

USED ON	SOLID	REV	TOLERANCES	DRAWN BY	DATE	ENGLISH		TorqMaster, Inc. Stamford, CT USA	
STANDARD	152	0.0	ENGLISH	RMF	8/30/00	MATERIAL		N/A	
NEXT ASSY	NONE		.XX ±.015 in .XXX ±.005 in .XXXX ±.0002 in	CHECKED BY	DATE	TITLE			
QUANTITY				DJC	8/30/00	HINGE INTERFACE			
PER ASSY, PCS	-		⊙			SIZE	ZE 375 CF 152		REV
TOTAL, PCS	-		◁			B			E
THIS INFORMATION IS PROPRIETARY TO TORQMASTER, INTL. THE POSSESSOR AGREES TO MAINTAIN IT IN CONFIDENCE, NOT REPRODUCING OR REVEALING IT IN WHOLE OR IN PART.						SCALE	1:1	SHEET	1 OF 1