

REVISION RECORD				
SYM	DESCRIPTION	BY	DATE	APPD
A	RELEASED FOR MFG.	RA	2/10	

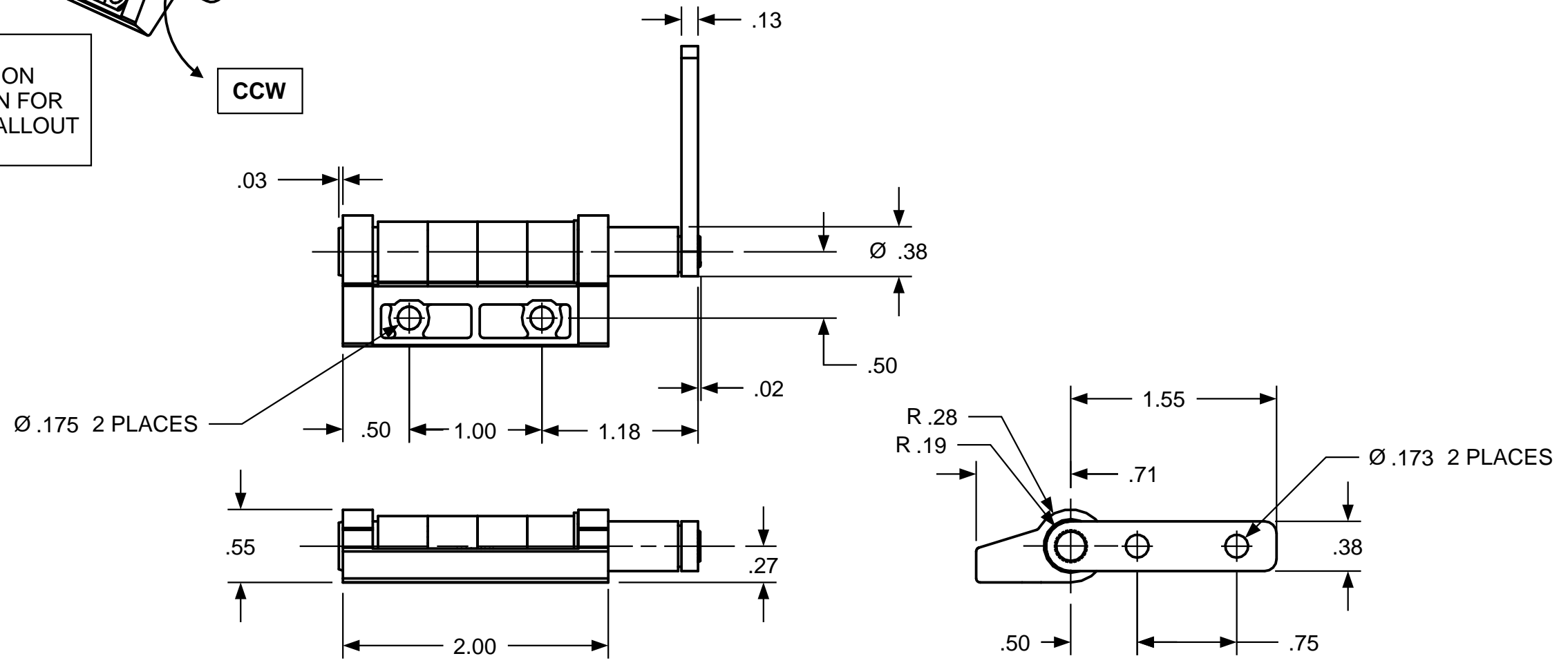
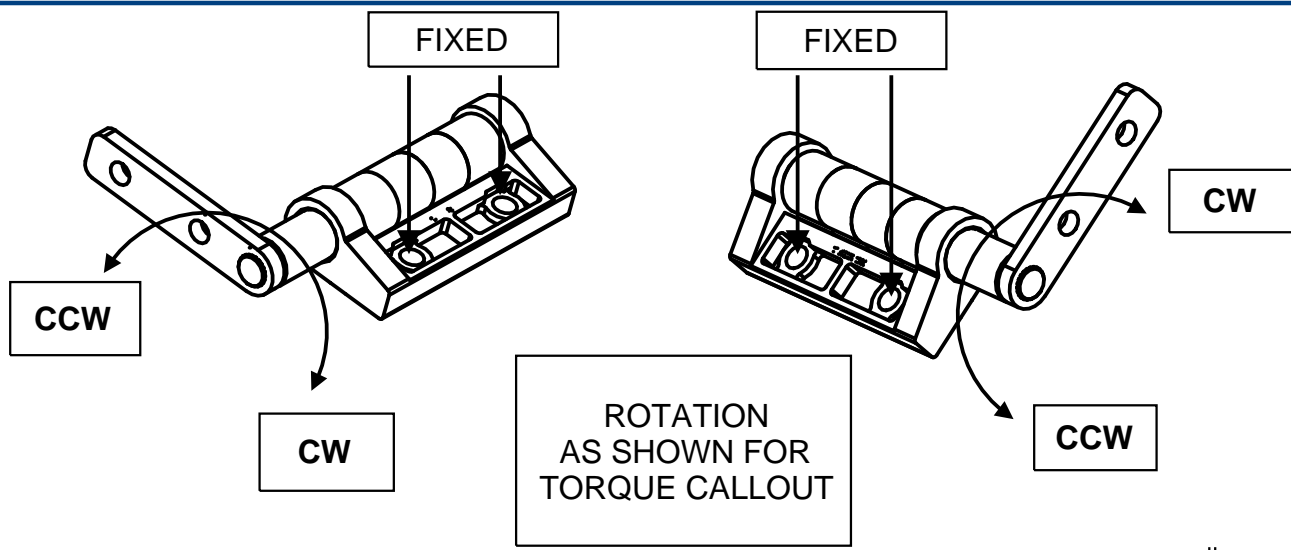

TORQUE

GEOMETRY	CW TORQUE	CCW TORQUE	HAND
ZE-375-SA-102	20	20	L
ZE-375-SA-102	20	20	R
ZE-375-SA-102	30	30	L
ZE-375-SA-102	30	30	R
ZE-375-SA-102	X	40	L
ZE-375-SA-102	40	X	R
ZE-375-SA-102	40	X	L
ZE-375-SA-102	X	40	R

CUSTOM TORQUE CONFIGURATIONS AVAILABLE. FOR QUOTE:
www.torqmaster.com
 1-888-41-HINGE

USED ON	SOLID	REV	TOLERANCES		ENGLISH / METRIC		TorqMaster INTERNATIONAL		200 HARVARD AVE STAMFORD, CT USA	
CUSTOM		0.0	ENGLISH	METRIC						
NEXT ASSY	N/A		.XX ±.015 IN	.X ±.3 MM	DRAWN BY	DATE	MATERIAL N/A			
QUANTITY			.XXX ±.005 IN	.XX ±.13 MM	RA	8-10-09	TITLE HINGE INTERFACE			
PER ASSY, PCS	-		.XXXX ±.0002 IN	.XXX ±.05 MM	CHECKED BY	DATE	SIZE	ZE 375 SA 102		REV
TOTAL, PCS	-		ANGLES ±0.5° SURFACE 63				B			A
THIS INFORMATION IS PROPRIETARY TO TORQMASTER, INTL. THE POSSESSOR AGREES TO MAINTAIN IT IN CONFIDENCE, NOT REPRODUCING OR REVEALING IT IN WHOLE OR IN PART.							SCALE	NTS	SHEET	1 OF 1