

REVISION RECORD

SYM	DESCRIPTION	BY	DATE	APPD
C	REVISED PER ECN 03097.	RMF	12/17/03	LH
D	REVISED PER ECN 018001.	RA	10/26/18	RA

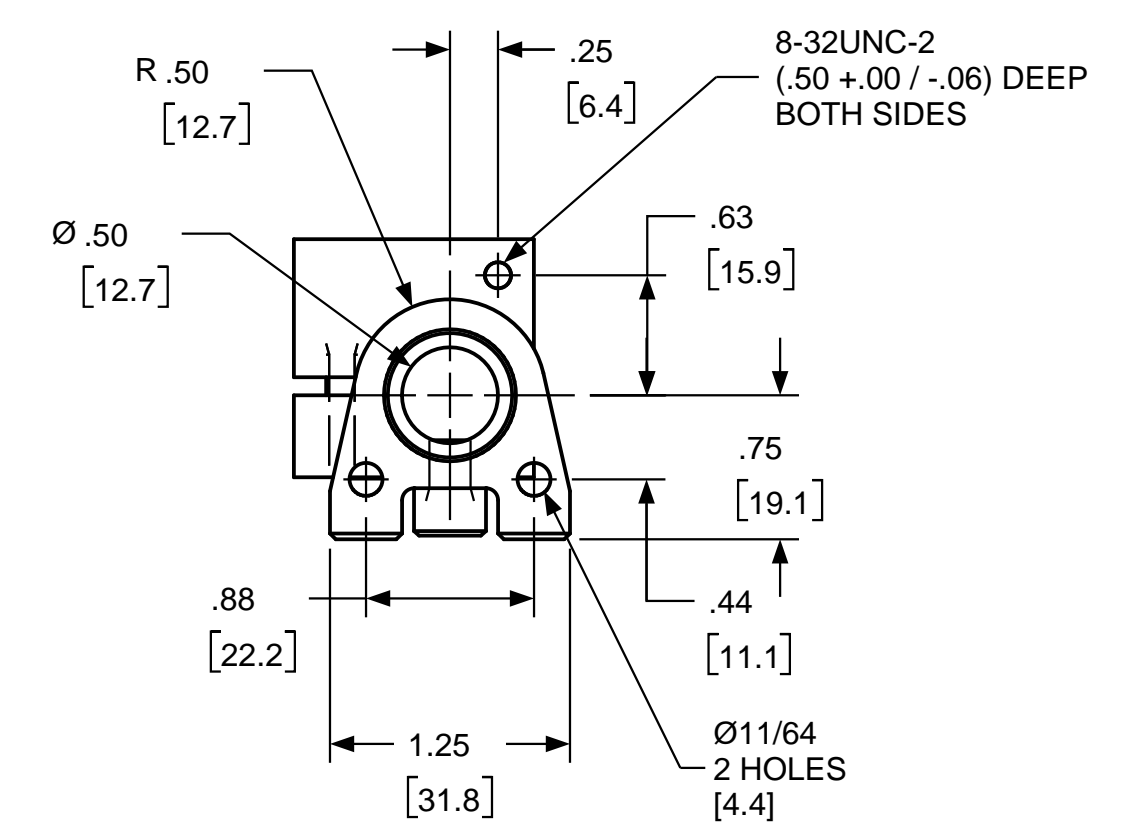
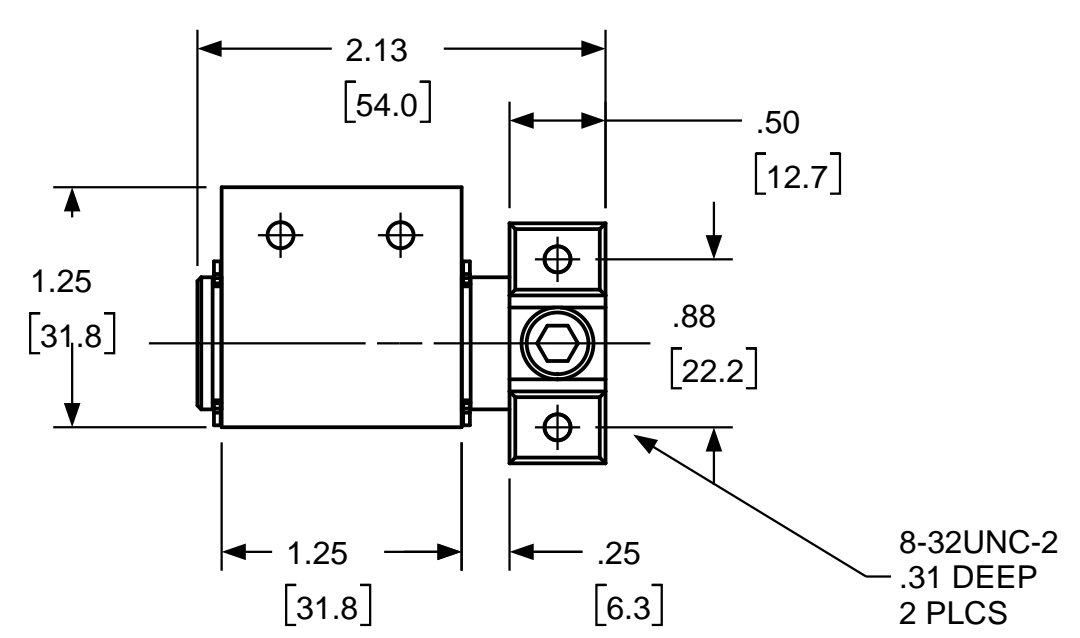
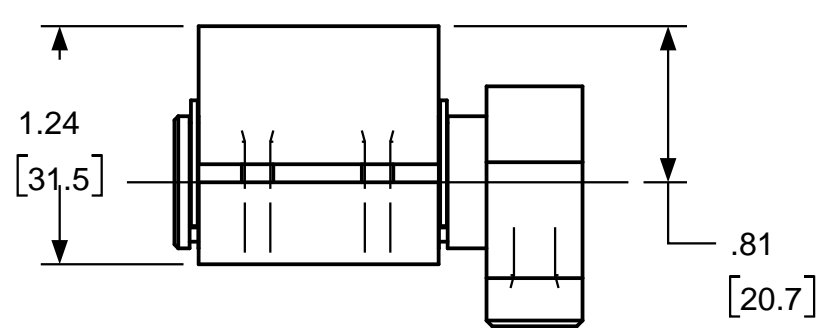
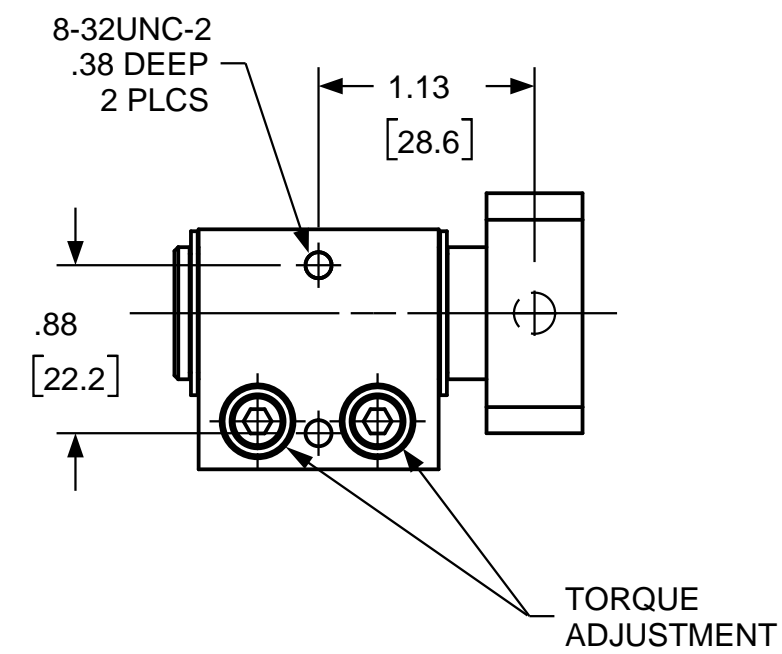
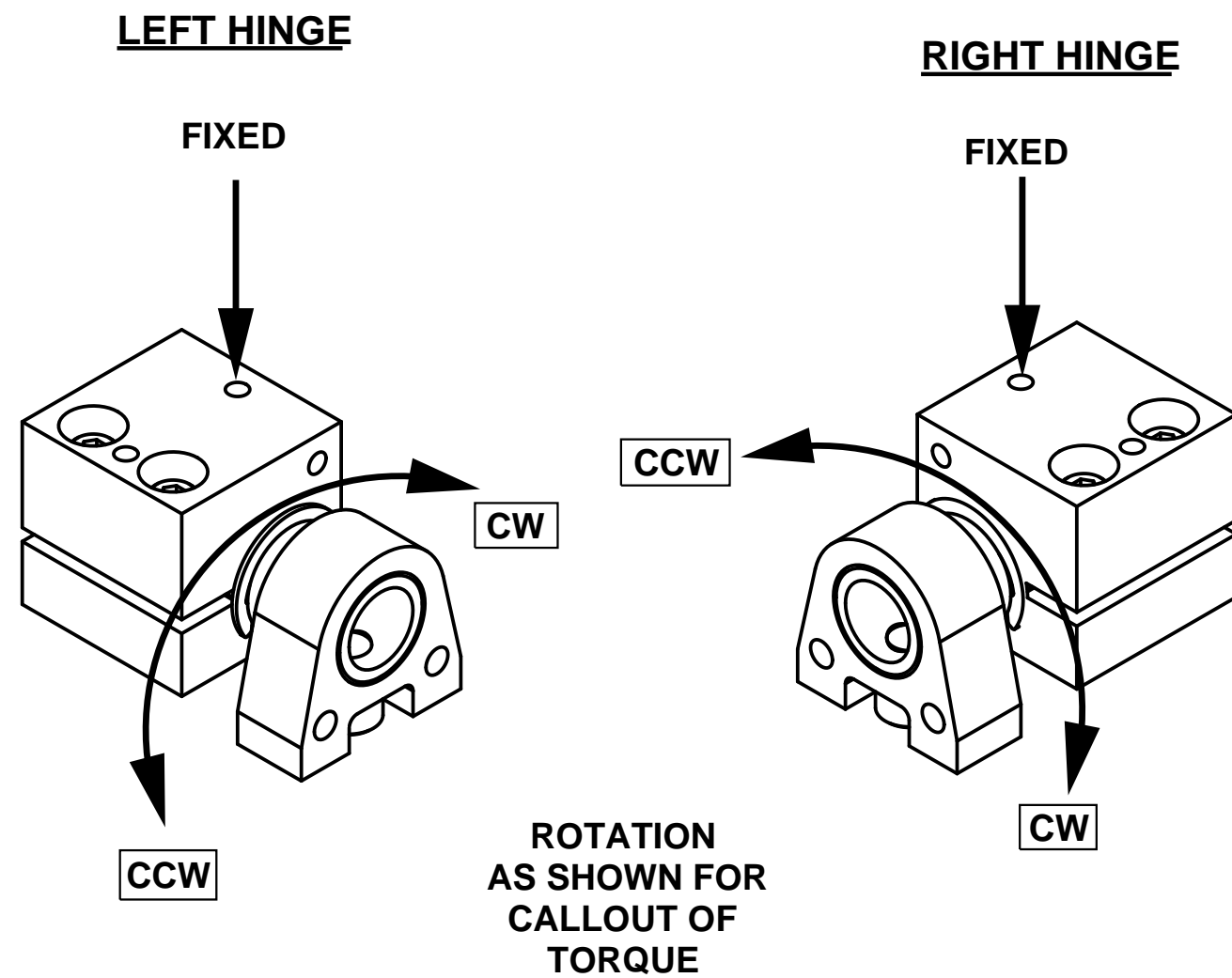

NOTES:

- HINGE TYPE: BALANCED.
- TORQUE ADJUSTABLE RANGE FROM 20 TO 100 lb. in (230 TO 1152 KG. MM.).

USED ON	SOLID	REV	TOLERANCES		ENGLISH / METRIC		TORQ MASTER INTERNATIONAL 200 HARVARD AVE STAMFORD, CT USA		
STANDARD	101	0.0	ENGLISH	METRIC	DRAWN BY	DATE	MATERIAL		
NEXT ASSY	N/A		.XX ±.015 IN	.X ±.3 MM	RA	6/3/97	N/A		
QUANTITY			.XXX ±.005 IN	.XX ±.13 MM	CHECKED BY		HINGE INTERFACE		
PER ASSY, PCS	-		.XXX ±.0020 IN	.XXX ±.05 MM	DJC	DATE	TITLE		
TOTAL, PCS	-		ANGLES ±0.5° SURFACE 63 <				SIZE	MA 685 MA 101	REV
THIS INFORMATION IS PROPRIETARY TOTORQMASTER, INTL. THE POSSESSOR AGREES TO MAINTAIN IT IN CONFIDENCE, NOT REPRODUCING OR REVEALING IT IN WHOLE OR IN PART.					SCALE		1:1	SHEET	1 OF 1