

FIXED TO DEFINE ROTATION

AVAILABLE TORQUES
(1.0 - 3.0)
INCH POUNDS

CW

CCW

REVISION RECORD				
SYM	DESCRIPTION	BY	DATE	APPD

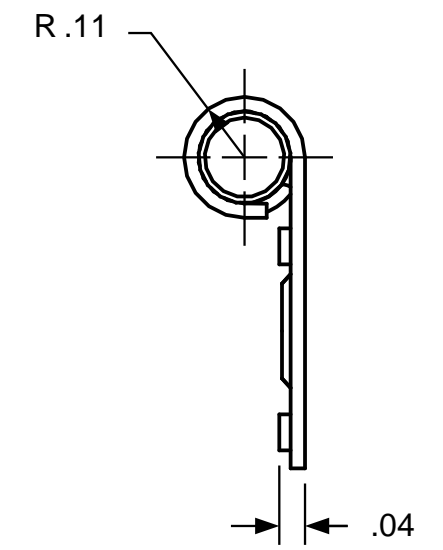
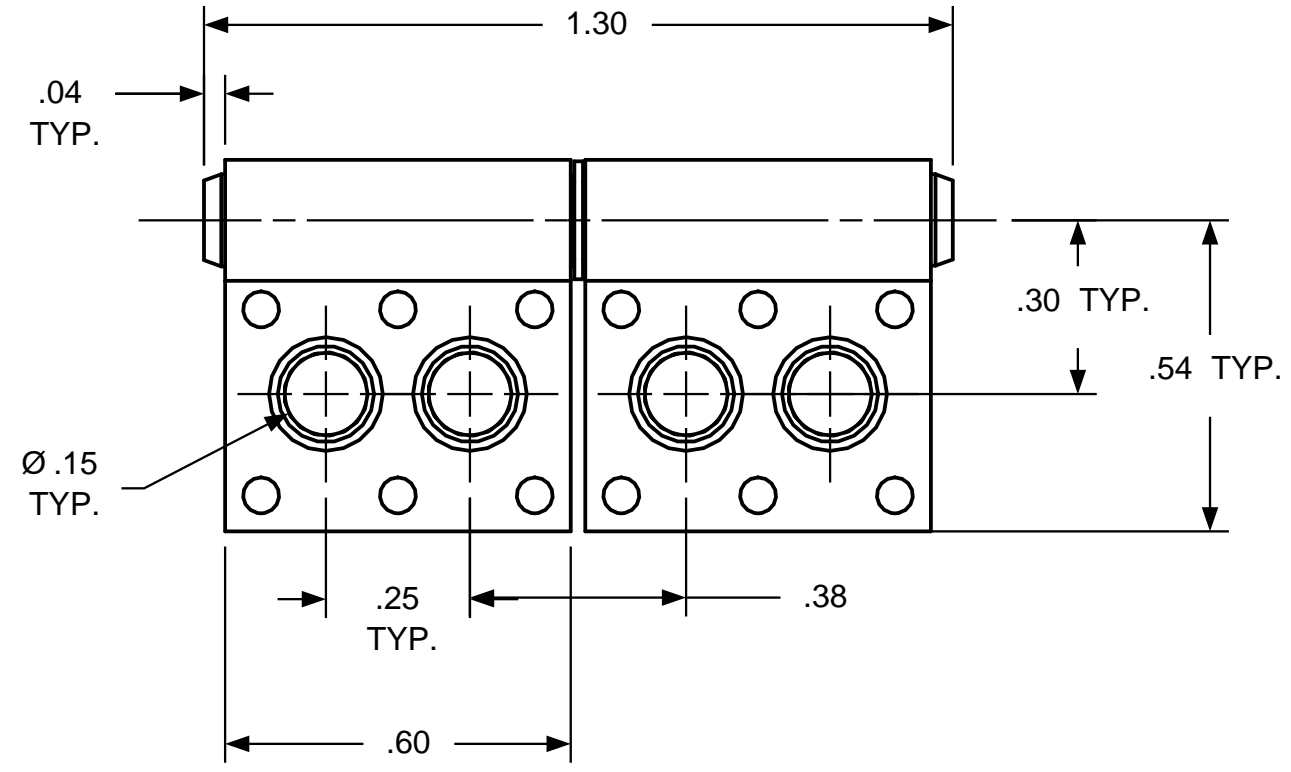

USED ON	SOLID	REV	TOLERANCES		ENGLISH / METRIC		TORQ MASTER INTERNATIONAL		200 HARVARD AVE STAMFORD, CT USA	
STANDARD	102	A	ENGLISH	METRIC						
NEXT ASSY	N/A		.XX ±.015 IN	.X ±.4 MM	DRAWN BY	DATE	MATERIAL N/A			
QUANTITY			.XXX ±.005 IN	.XX ±.13 MM	RA	10/4/23	TITLE HINGE INTERFACE DRAWING			
PER ASSY, PCS			.XXXX ±.0002 IN	.XXX ±.05 MM	CHECKED BY	DATE	SIZE B		REV A	
TOTAL, PCS								SCALE NTS		SHEET 1 OF 1
THIS INFORMATION IS PROPRIETARY TOTORQMASTER, INTL. THE POSSESSOR AGREES TO MAINTAIN IT IN CONFIDENCE, NOT REPRODUCING OR REVEALING IT IN WHOLE OR IN PART.										