

REVISION RECORD

SYM	DESCRIPTION	BY	DATE	APPD
B	REDRAWN ON NEW FORMAT, NO CHANGES.	RMF	4/18/01	DJC
C	REVISED FOR ALTERNATE SHAFT PROCESSING	RA	01/10	

LEFT HAND

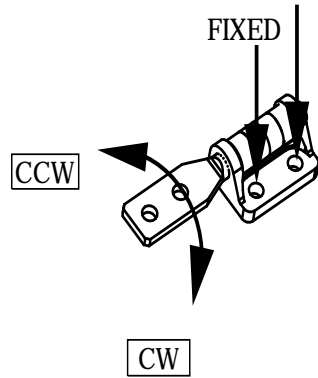

RIGHT HAND

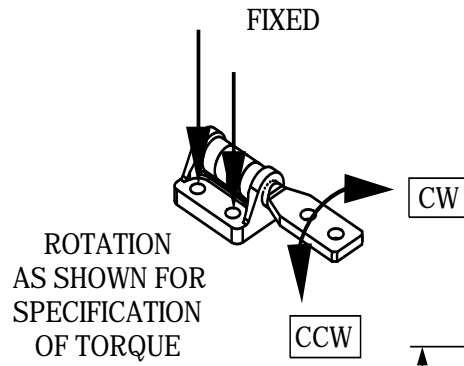

TORQUE

GEOMETRY	CW TORQUE	CCW TORQUE	HAND
ZE-188-CF-114	-5	-5	-L
ZE-188-CF-114	-5	-5	-R
ZE-188-CF-114	-8	-8	-L
ZE-188-CF-114	-8	-8	-R

CUSTOM TORQUE CONFIGURATIONS AVAILABLE. FOR QUOTE: www.torqmaster.com 1-888-41 HINGE

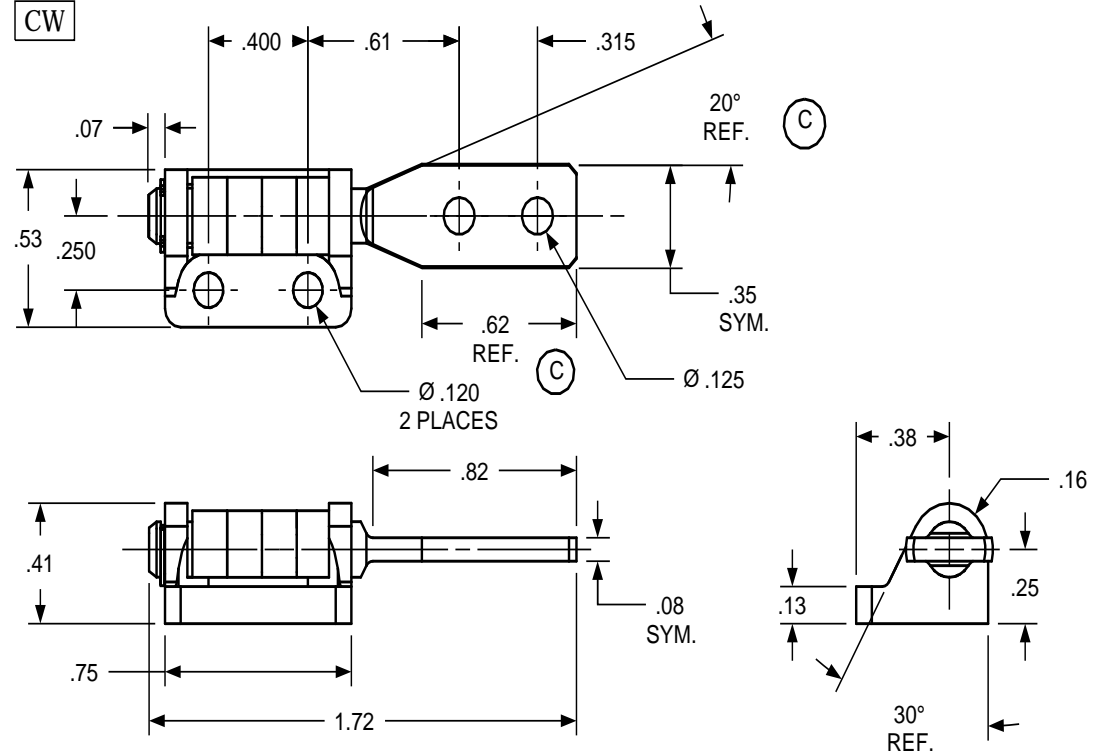

USED ON	SOLID	REV	TOLERANCES	DRAWN BY	DATE	ENGLISH		TorqMaster, Inc. Stamford, CT USA	
STANDARD	114	C	ENGLISH	RA	5/9/97	MATERIAL		N/A	
NEXT ASSY	NONE		.XX ±.015 IN .XXX ±.005 IN	CHECKED BY	DATE	TITLE			
QUANTITY				DJC	5/9/97	HINGE INTERFACE			
PER ASSY. PCS	-					SIZE	ZE 188 CF 114		REV
TOTAL. PCS	-					B			C
THIS INFORMATION IS PROPRIETARY TO TORQMASTER, INTL. THE POSSESSOR AGREES TO MAINTAIN IT IN CONFIDENCE, NOT REPRODUCING OR REVEALING IT IN WHOLE OR IN PART.				SCALE		NTS		SHEET 1 OF 1	